

RES SOPzV Advanced Batteries for Renewable Energy Storage



BATTERIES



SOLAR PV



WIND



GENSET



GRID



SUNLIGHT

RES SOPzV OVERVIEW

Advanced Maintenance-Free Tubular Plate GEL Batteries for Renewable Energy Storage

RES SOPzV is an **advanced energy storage solution** ideal for autonomous/hybrid PV systems in residential, telecom or infrastructure installations where demand for **no water refilling** and **long cycle life** is essential.

Enhanced valve regulated technology with **electrolyte in GEL form** and high performance **tubular positive plates** are used to produce an exceptional combination of benefits in a single battery.

APPLICATIONS

- **Residential Installations**

Off-grid or smart grid connected power systems electrifying houses, hotels, hospitals, schools or factories.

- **Infrastructure PV systems**

Remote telecom stations, water pumping, oil & gas distribution, traffic signaling, road lighting, telemetry, security systems.

PRODUCT FEATURES & BENEFITS

- **Long cycle life**

Tubular positive plates and GEL electrolyte technology provide unique advantages in prolonging cycling operation to a 60% DoD cycle life of 2000 cycles at 20°C.

- **Performance and reliability**

Optimum design, special lead calcium alloys composition, exclusive use of high quality materials and state of the art European manufacturing facilities ensure high capacity performance, efficiency and reliability.

- **Easy maintenance**

Maintenance-free design with internal pressure relief valve ensures no site visits for topping up.

- **Operational safety**

Extensive compliance testing performed under European and Global norms verified by independent 3rd party certification agencies.

- **Complete & flexible energy storage solution**

Fast delivery of modular battery systems with all the necessary accessories for safe installation in trays.

- **Optimum Total Cost of Ownership (TCO)**

Significant benefits in terms of cost per cycle and lifetime value maximization.

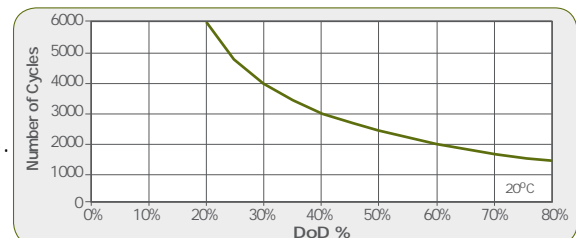

The ideal energy solution for Renewable Energy Storage applications

PRODUCT RANGE

2V Cell Type	Capacity (Ah at 20°C)				Dimensions				Weight kg	Internal Resistance (mOhm)	Short Circuit Current (A)
	C120 Uf=1.85V	C48 Uf=1.80V	C24 Uf=1.80V	C12 Uf=1.75V	Length (mm)	Width (mm)	Height ₁ (mm)	Height ₂ (mm)			
RES 2 SOPzV 150	150	145	135	126	198	47	343	370	9.0	1.58	1280
RES 3 SOPzV 225	225	218	203	189	198	65	343	370	12.7	1.08	1900
RES 2 SOPzV 280	284	279	260	244	198	47	568	595	15.4	1.08	1900
RES 3 SOPzV 425	426	419	390	366	198	65	568	595	22.0	0.72	2840
RES 4 SOPzV 565	568	558	520	488	198	83	568	595	28.7	0.54	3780
RES 5 SOPzV 710	710	698	650	611	198	101	568	595	35.3	0.43	4740
RES 6 SOPzV 850	852	838	780	733	198	119	568	595	42.1	0.36	5680
RES 7 SOPzV 990	994	977	911	855	198	137	568	595	48.8	0.31	6620
RES 8 SOPzV 1135	1136	1116	1041	977	198	155	568	595	55.5	0.27	7580
RES 7 SOPzV 1190	1190	1171	1087	1024	198	137	713	740	60.0	0.31	6560
RES 8 SOPzV 1360	1360	1338	1242	1170	198	155	713	740	68.1	0.27	7500

Technical details may be subject to alterations.

DRAWINGS

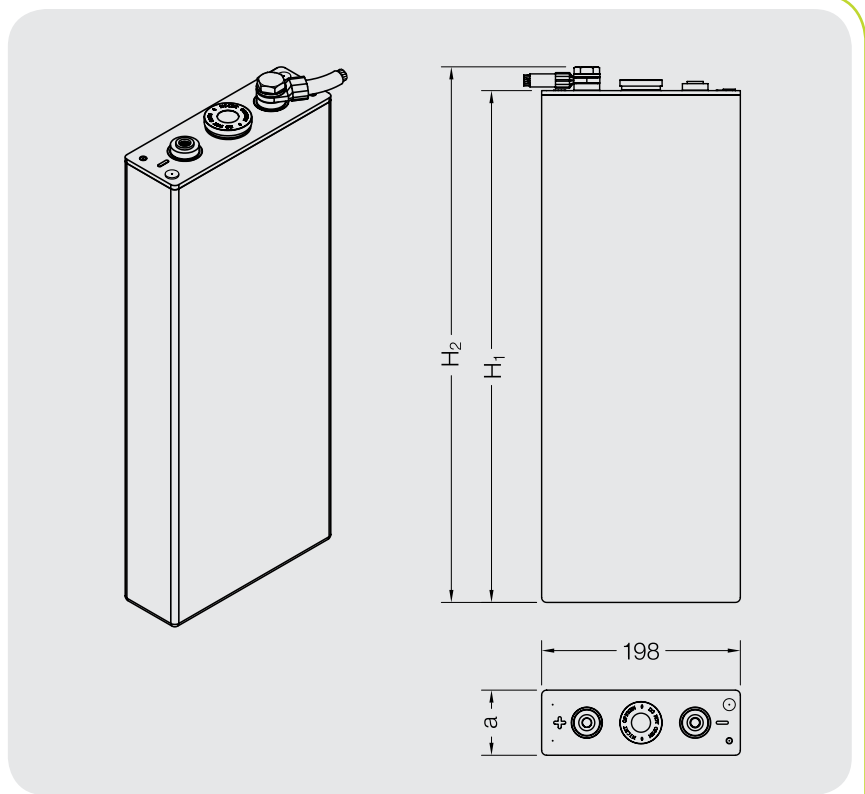

CERTIFIED QUALITY

- Manufactured at SUNLIGHT's European production facilities, certified with ISO 9001, ISO 14001, BS OHSAS 18001.
- Compliant with IEC 61427 requirements for photovoltaic energy systems.
- Tested according to IEC 60896-21 and fully compliant with IEC 60896-22 requirements.
- Compliant with the safety requirements of EN 50272-2.

TECHNICAL FEATURES AND BENEFITS

1 Positive Plates

- Tubular plate design
- Optimized Lead Calcium Tin Alloy reducing hydrogen evolution
- Red Lead in-house production by 99.99% Pure Lead
- Dry Filling process

- ✓ Long cycle life
- ✓ Excellent cycling properties
- ✓ Quality and homogeneity
- ✓ High capacity performance
- ✓ Reduced corrosion
- ✓ Reduced self-discharge rate
- ✓ Increased tolerance even in cases of poor charging conditions
- ✓ Wide operational temperature range

2 Negative Plates

- Pasted negative plates of grid design
- Paste mixture that ensures high adherence and cohesion
- Optimized corrosion resistant Lead Calcium Tin Alloy
- Robust construction
- Long life expander

- ✓ Stability
- ✓ Increased cyclic performance
- ✓ Long battery life

3 Separators

- Manufactured from microporous silica-based PVC material
- Allow migration of ions during charge/discharge
- More acid in the surrounding area of the plates

- ✓ Secured protection against short circuits
- ✓ High temperature stability
- ✓ Mechanical strength
- ✓ Low internal resistance

4 Gauntlet

- Highly microporous material
- Fine pore structure
- Low electrical resistance

- ✓ Effective active material retention
- ✓ Eliminates active mass shedding

5 Bottom Bar

- Ultrasonic welding

- ✓ More secure fitment with gauntlet
- ✓ Growth of positive spine into bottom bar's cavity is easily accommodated
- ✓ Retains active material on the spines

6 Electrolyte

- Sulphuric acid immobilized in GEL form
- State of the art GEL filling equipment
- High purity silica for GEL formation
- Effective diffusion of GEL

- ✓ Operation without acid stratification or dendrite growth
- ✓ High performance on deep discharges
- ✓ Low self discharge

7 Cell Container

- High impact resistant Polypropylene for the container
- Lid welding, trimming and tightness control

- ✓ Long term leakage free operation
- ✓ Unsurpassed mechanical strength
- ✓ Robust and durable battery construction

10 Pole Bridge

- Terminal bridge manufactured with Cast On Strap process

- ✓ Consistent and uniform pole bridge composition
- ✓ Increased robustness and durability
- ✓ Perfect connection for poles-bridge-plate block as a whole

9 Pole Terminal

- Advanced design of pole post and its sealing to the lid. Rubber ring with optimized hardness and acid resistance

- ✓ Operational safety
- ✓ Perfect sealing
- ✓ Low maintenance requirements
- ✓ Better current conductivity
- ✓ Positive plate's expansion is safely absorbed
- ✓ Prevention of top lid cracks and acid leakages

8 Valve

- Maintenance-free design
- Pressure relief
- Integral flame arrestor

- ✓ No topping-up required
- ✓ Increased safety

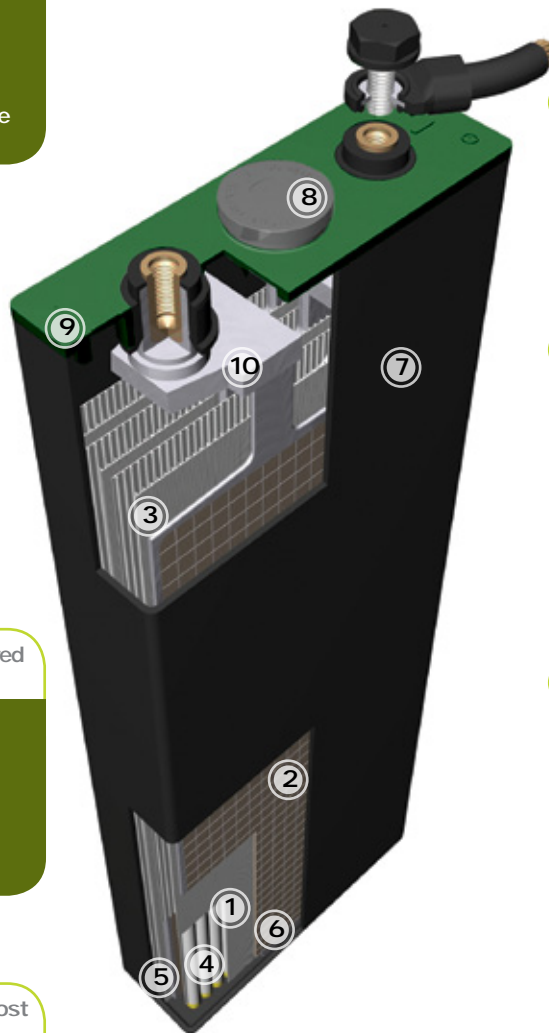

 **SUNLIGHT**

